

Equipment Description

Danco's steel and stainless steel, semi-nozzle angle relief valve with flanged connections uses spring force to hold the disc against the seat to close the valve. The spring force is adjusted to the specified set pressure. Should the pressure in the system rise above the set pressure, the force it exerts on the disc is more than the spring force. This unbalanced condition causes the spring to compress and the disc to move away from the seat opening, thus opening the valve.

Installation

Safety Precautions

Do not install these valves in a system where pressure and/or temperature conditions exceed the specification of the individual valve. Serious personnel injury or death may result if system valves are not closed.

Installation Instructions

Thoroughly clean all end connections of the pressure pipe, outlet pipe and valve body prior to performing the following connection procedures. Once all connections are cleaned, complete the following steps to install the valve:

- Place the valve in position and check the alignment of the system piping. The valve pressure inlet port is at the bottom of the valve, the outlet port is at the side. Correct any misalignment that will place strain on the valve when installed.
- Install the proper gasket between the inlet and outlet flange joints.
- Install the proper flange bolts. Torque bolts to specification.

Installation Checkout

- Be sure there are no restrictions at the valve inlet or outlet.
- Pressurize system to 75% of the set pressure on the data plate attached to the valve.
- Check valve connections for leaks.
- Manually test valve operation as outlined in the following table.

Operation

Normal Operation

The angle relief valves described in this manual are automatically operated by system pressure. Outside controls or operators are not required.

Test Mode

To test an installed relief valve, increase the system pressure to the relief valve's set pressure, causing the valve to open. If this procedure is not feasible, the relief valve may be manually tested. To manually test the valve, follow instructions in table titled "Operating Procedures".

Valve Handle

All Danco Valve Company angle relief valves are equipped with a handle (unless otherwise specified). The handle is designed to manually test valve operation while the valve is installed in the system.

MAINTENANCE MANUAL – STEEL & STAINLESS STEEL, SEMI-NOZZLE ANGLE RELIEF VALVE

Operating Procedures

Description	Procedures
Normal Operation	Operating procedures are not required (automatic operation).
Manual Operation	Manually operate the relief valve as follows:
	1. Increase the system pressure to a minimum of 75% of the valve set pressure.
	2. Rotate the handle clockwise to open the valve. A sudden reduction of the system pressure indicates the valve is open.
	3. After test is complete, release the handle to the closed position to conclude manual test.

Troubleshooting

Angle relief valves could malfunction in one or more ways; external leakage, handle non-operative, failure to open, failure to close or internal leakage. The following chart lists possible malfunctions, probable cause for malfunction and instructions for remedying the fault.

Angle Relief Valve Troubleshooting

Symptom	Possible Cause	Remedy
External Leakage	End connections loose, loose valve assemblies, damaged seals, porosity	Tighten the end connections. Verify the torque specifications of all assemblies. Replace seals. If leakage continues, contact the manufacturer.
Internal Leakage	Damaged seat and/or disc subassembly	If the valve leaks when properly closed, damage has occurred to the seat, and/or disc subassembly. Contact the manufacturer.
Handle Non-Operative (Handle will not rotate to open the valve)	Internal damage or foreign material	Contact the manufacturer.
Failure of Valve to Open at Specified Pressure	Damage to or foreign material in the bonnet subassembly	Contact the manufacturer.
	Damage to or foreign material in the disc subassembly	Contact the manufacturer.
Failure of Valve to Close at Specified Pressure	Damage to or foreign material in the bonnet subassembly or disc subassembly	Contact the manufacturer.
	Damage to or foreign material in the bonnet subassembly and/or between disc and seat.	Contact the manufacturer.

MAINTENANCE MANUAL – STEEL & STAINLESS STEEL, SEMI-NOZZLE ANGLE RELIEF VALVE

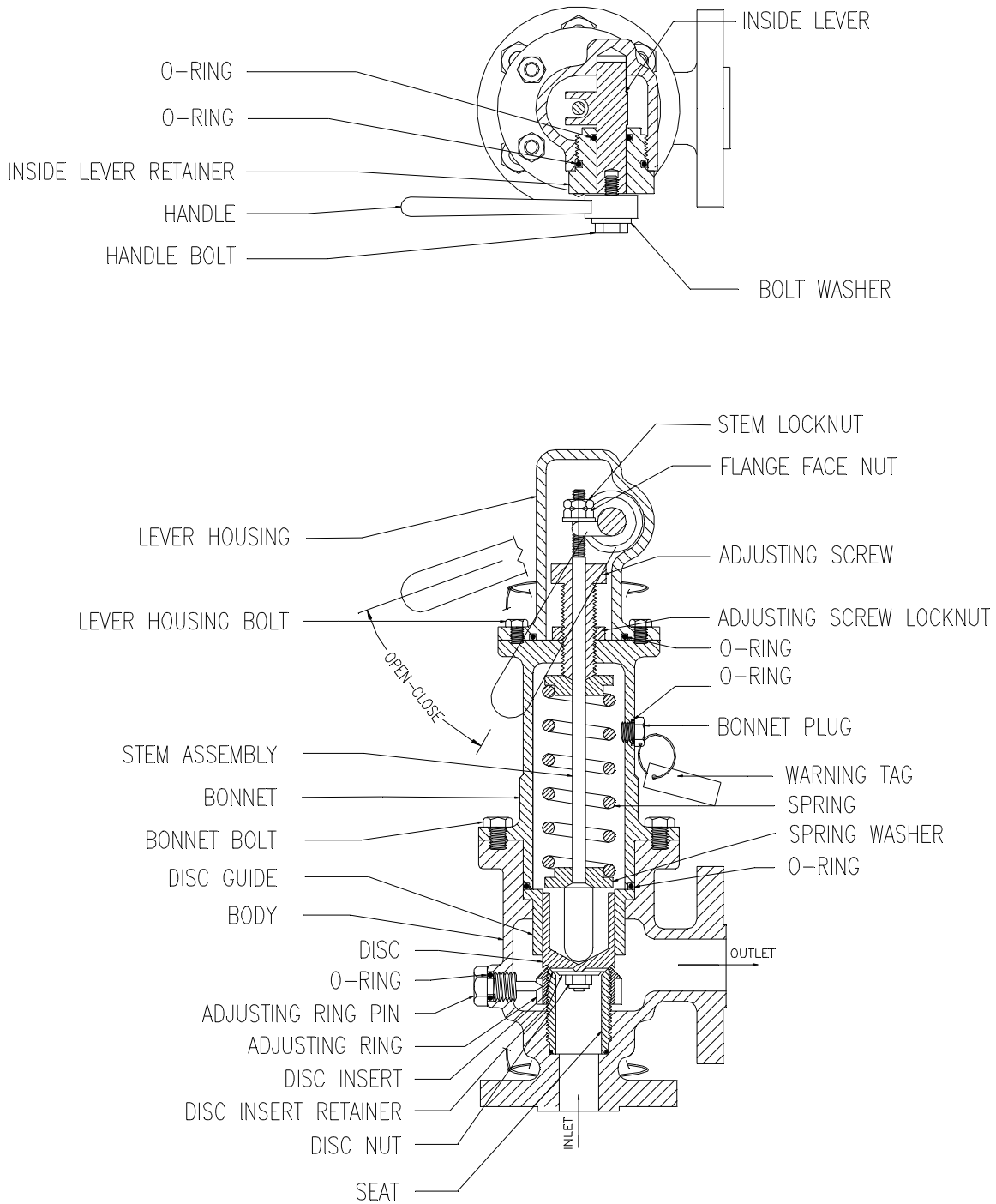

Typical cross section view - Steel & Stainless Steel semi-nozzle, enclosed spring flanged relief valve

MAINTENANCE MANUAL – STEEL & STAINLESS STEEL, SEMI-NOZZLE ANGLE RELIEF VALVE

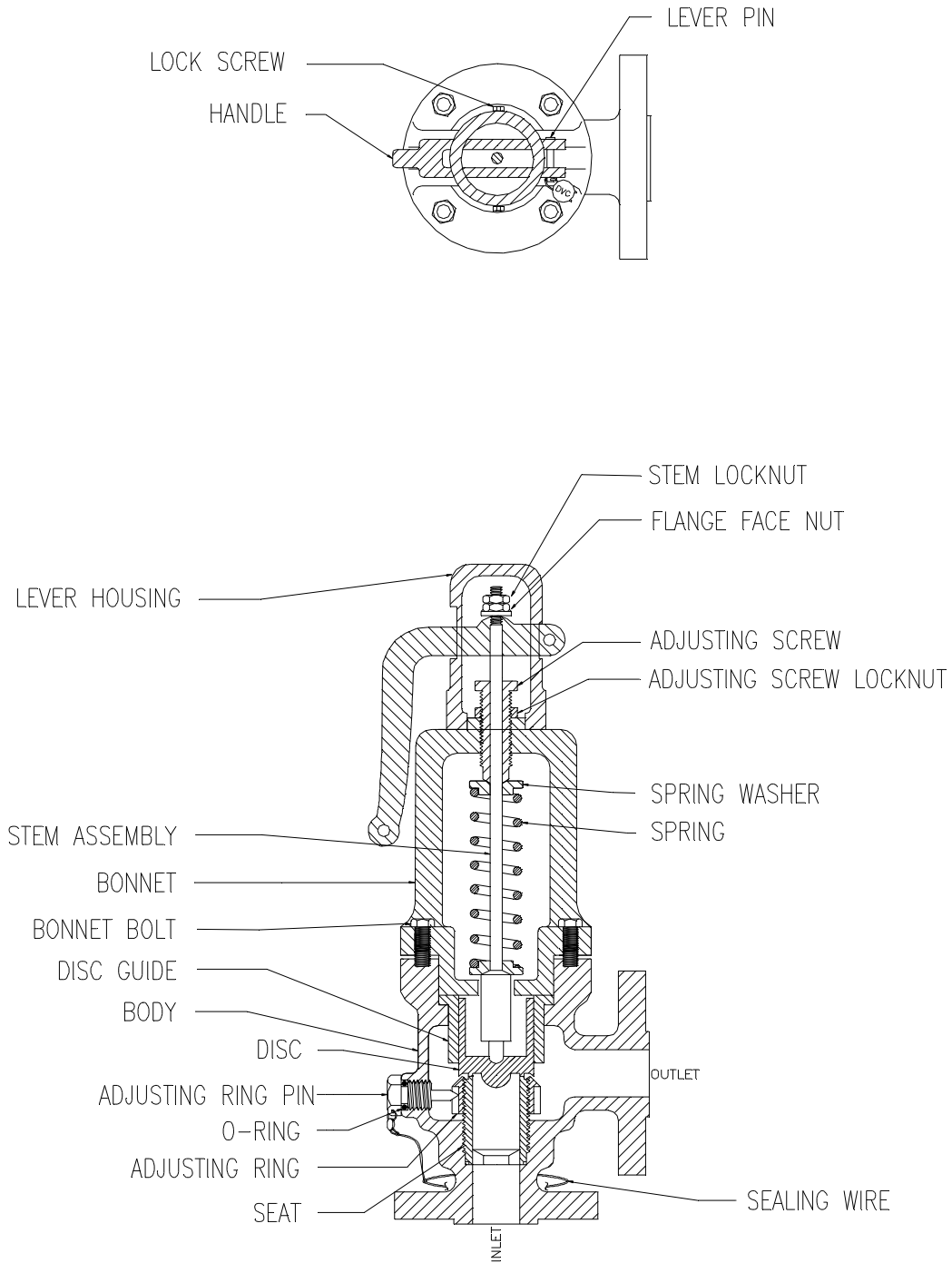

Typical cross section view - Steel & Stainless Steel semi-nozzle, exposed spring flanged relief valve